

Construction Notes for the Tube CO2 compressed air engines.

7/22/2004

This is a set of photos and notes that should help better understand the parts and drawing used in this engine. The notes are primarily for the single cylinder engine but are also appropriate for the 3 cylinder radial.

The engine is made from materials available at the hardware store. I used the lathe and mill but it is obvious that with some care this entire engine could be built with a drill press and hand tools.



Cut the slot in the piston rod.



Cross drill the piston at 90 degrees. Do it all in one clamping if possible. Parts are small so center drill everything.



Use a razor saw and miter box to cut the tubes. Be sure to debur everything.

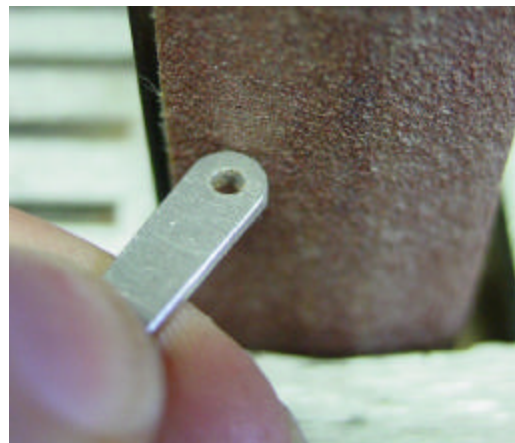

The ends of the connecting rod are just filed or sanded to shape.

Construction Notes for the Tube CO2 compressed air engines.

7/22/2004



All the piston parts. When the tube is glued to piston center the wrist pin is captive. The connecting rod is tapered to allow it to move over a wide enough angle for the crank.



A length of brass had the hole for the crank pin drilled and 2 cuts made for some balance.

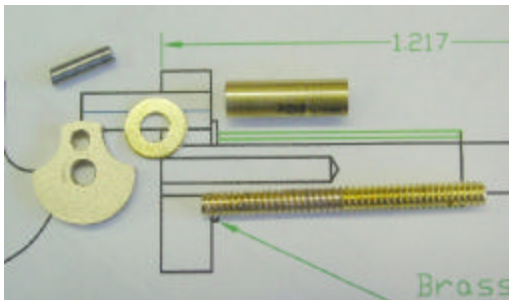

The crank is made of the 2 layers of tube, a cut off 6-32 screw. The screw needs to have some of its threads filed down to fit in the first tube. Now is the time to drill the axial hole in the screw

for the exhaust. Solder the tube to the screw and the shaft to the crank end.

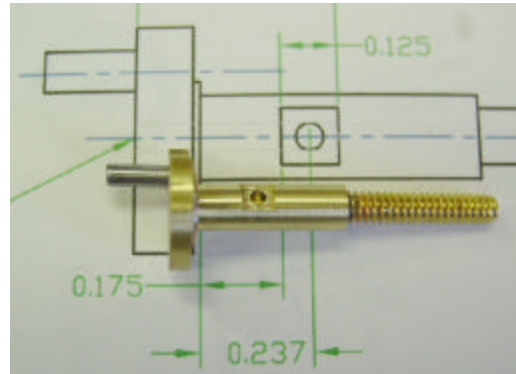

Make the small exhaust flat. Drill the hole to the center hole.

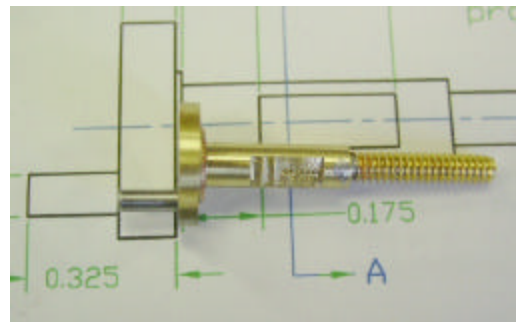

Flip the shaft and make the longer input flat.

A multi cylinder version needs a way for the input air to reach the valve flat regardless of the shaft angle. This is done by cutting a groove shown on the radial drawing.

Construction Notes for the Tube CO2 compressed air engines.

7/22/2004



The outer valve body is 2 layers of tube. The inner one is drilled 1/16 and the outer one id driller #41 (.096) to accept the OD of the copper tube to be soldered to it. They get soldered together

For the multi cylinder version, multiple holes are needed for the copper tubes going to the cylinders.

The valve will accept as many tubes as you can add. It may take a few minutes to figure out how it just works.

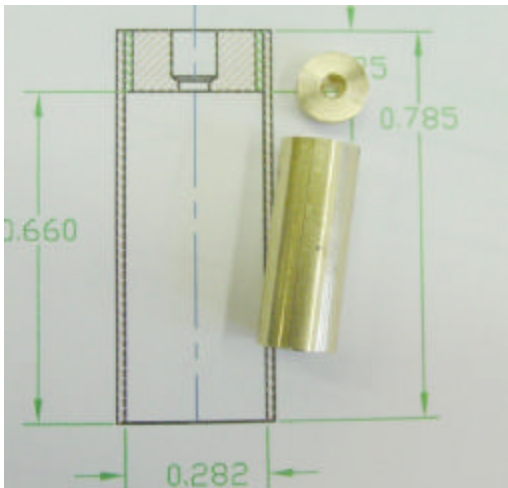

The cylinder is a tube with an end cap made to accept the copper tubes.



The frame sides are cut out. A concave form is made to make the curved areas.



Solder up the base.

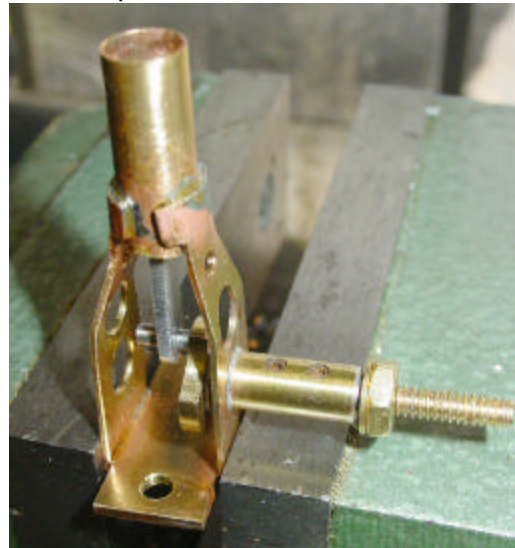

Solder the cylinder in place so there is .015 gap inside the cylinder at TDC.

Construction Notes for the Tube CO2 compressed air engines.

7/22/2004

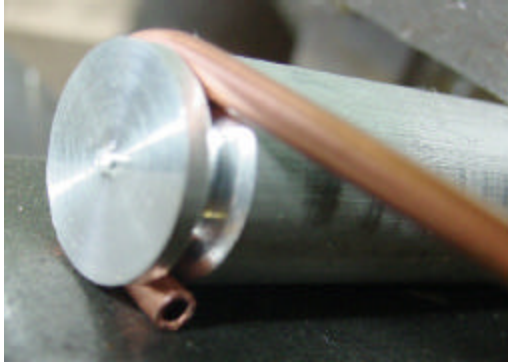

Make a tube bender and form the J.

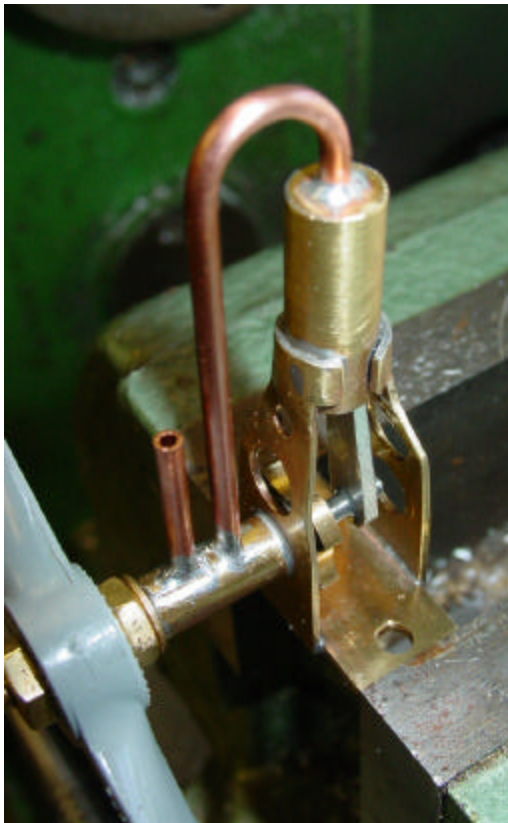

After getting rid of the excess solder it is done.

Initially with the excess solder the J tube was clogged. It would not run.

When the tube was clear, the engine feels very strange. There is no compression, it just spins.

The rotary valve is very simple. At about 30 degrees after TDC the long slot allow the compressed air into the cylinder. The compressed air pushes

the cylinder down for about 100 degrees. For the remainder of the down stroke the air expands and continues to push. At about 30 degrees into the upstroke, the exhaust port opens and the piston pushes air out the center of the crank shaft. After about 100 degrees the valve closes to get ready for the next power stroke. The angles are not precise and the operation of the valve is not exact.

This is a simple and efficient valve.

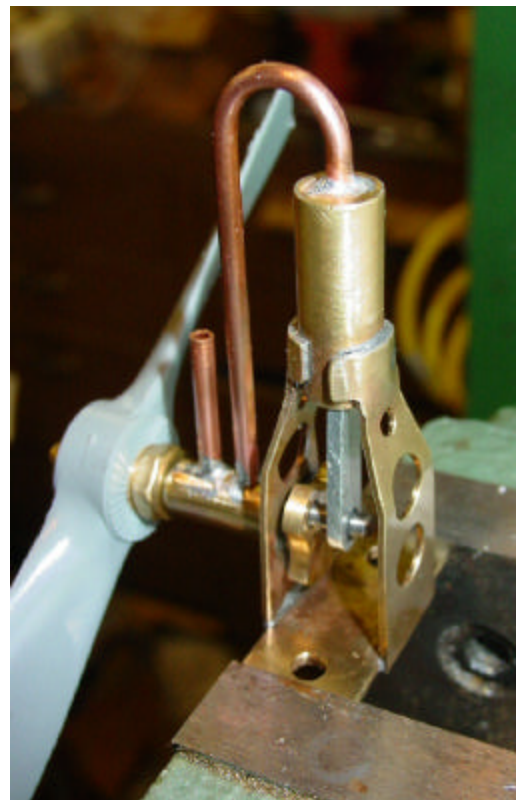

Looking at this view you can see where 2 more connecting rods would go to make the 3 cylinder radial.

Have fun with this design it is simple flexible and tolerant. Clearances are large but who cares if it leaks a little when it is running great.