

Modular Engine 1, 2008 revision

August 3, 2008

David Kerzel

© 2008

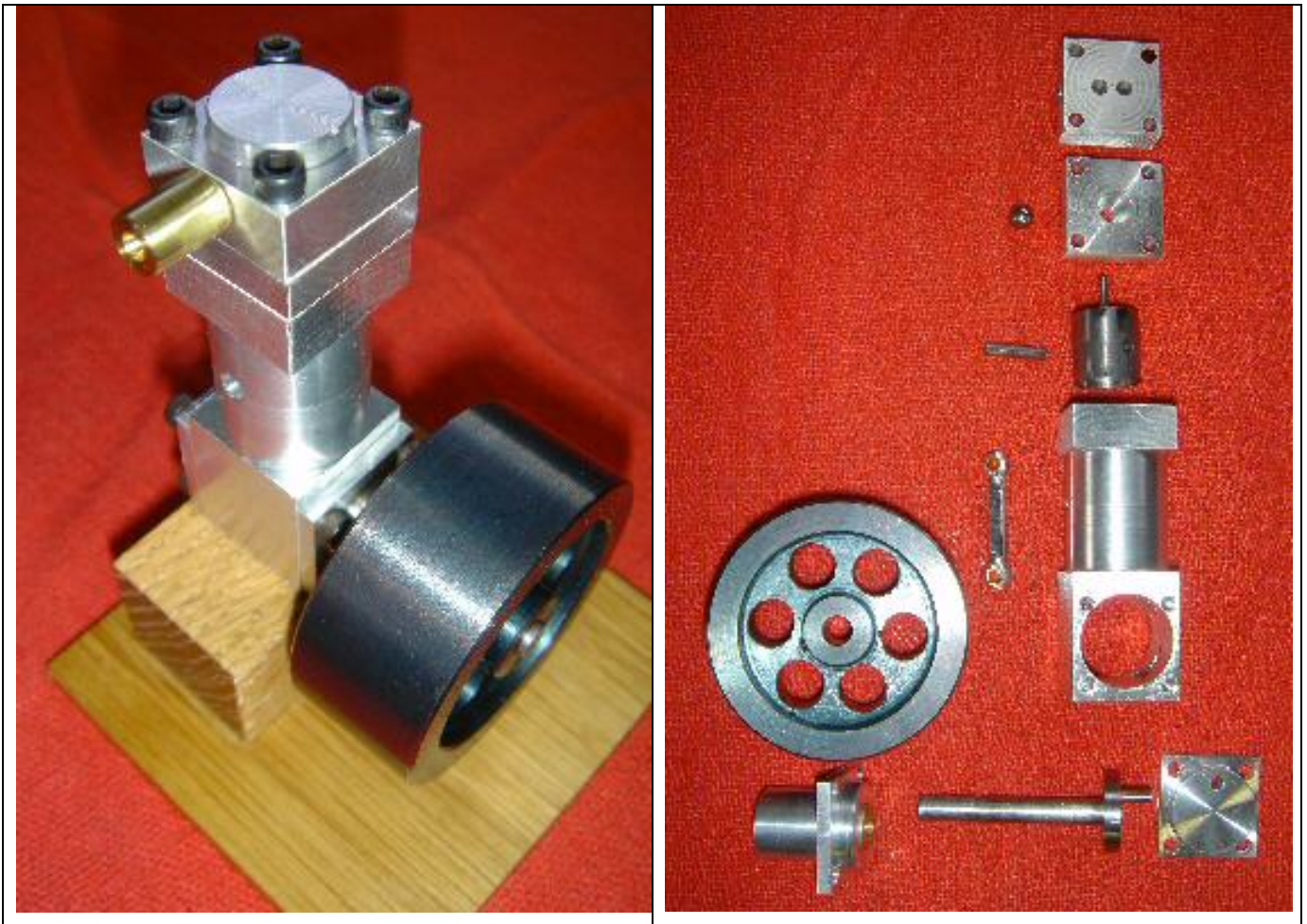

Back in 2002 I wanted to build a bunch of different engines without a lot of detail to learn how to build an engine, what works and what does not work. Modular 1 was the first in the series. It is a simple CO2 type that ended up with a lot of difficult details because it was the first one. When I finished it, I started building smaller versions and then multi cylinder versions.

This is a new version of that first engine. It has been streamlined so it can be built on a small lathe like a Sherline. A 3 and 4 jaw chuck are needed, as is a drill press. It is intended as a first engine or as a fun fast build that leads to more complex air operated engines. The design can be scaled up or down, or built with no detailed plans. There are no complicated valves or valve timing involved so all energy can go to design and details.

CO2 engines operate at higher pressures than many people expect. Even though the engines are often little they need high pressure to run. It's not about friction in the engine it is just how the engine cycle works.

When the piston moves up past the exhaust ports in the cylinder it is compressing the air in the cylinder. This engine has a 2.9:1 compression from exhaust ports to TDC so the pressure peaks at 29 PSI (if there are no leaks). If the supply pressure is less than the compression pressure the engine will act as a compressor and pump air out the inlet port. With a supply of 30 PSI or more, the supply pressure keeps the valve ball seated just like a check valve, no air flows. Just before TDC is reached the pin pushes the ball open and increases the pressure in the cylinder to 30 PSI. This is actually only a 1 PSI increase over the compression pressure. As the cylinder moves down the air expands and drops to about 1 PSI when it hits the exhaust port. The engine is almost silent if everything is in balance. Nearly 95% of the energy in the compressed air is used.

Higher pressure causes the engine to run faster and produce more power. It gets louder and the energy efficiency drops off rapidly. When one of these engines operates on low pressures, it indicates the piston/cylinder is leaking and not fully compressing the air. If they need higher pressure, it is due to friction and will hopefully break in.

Construction Notes: The following construction notes are how I decided to build this engine. There are many other ways to make each of the parts. Some of my choices may not be applicable to your tools and machines. Feel free to change everything.

Hardware:

Quantity	Description
1	3/16 SS ball
8	4-40 X ¼ inch Allen Cap Screws
4	4-40 X 5/8 inch Allen Cap Screws
1	4-40 X 1/8 inch Set Screws

I used high strength screws because that's what I had but any common 4-4 screws are fine.

Cylinder with Exhaust: The cylinder is made from ¾ square 6061 aluminum stock. Put it in the 4 jaw chuck and turn one long side flat removing about 0.010. The concentric tool marks from turning will show up in the finished engine so take time to center the part in the chuck. Rotate the part 90 degrees to do the next face. Be sure to use a scrap of thin aluminum or brass to prevent the chuck jaw from damaging the newly turned surface. The flat and true square surfaces in the chuck jaws will cause the resulting part to be flat and square. When the third and fourth sides are faced, take care to properly size the part. When the part is square, mount it in the 4 jaw chuck length wise, and then turn the bottom end clean and flat. Reverse the part making sure centering is less than 0.002 TIR, turn to length and center drill. Use a live center while turning the center portion of the cylinder OD which is basically decorative and can be left square or have fins if you wish. First drill then bore the cylinder bore leaving it slightly undersize 0.499/0.498. Layout the holes for the crank shaft and the rear mounting screws. I recommend drilling and tapping the screw holes and adding a pilot hole for the crank shaft next. This is a good time to add the holes in the top and bottom as well. Drill the exhaust port. Return the cylinder to the lathe, line up the pilot hole for the crank shaft, insure it is centered on the cylinder body and then drill and bore it to size.

Piston: The piston can be made of aluminum or ½ inch drill rod. I used drill rod last time, it is ground round and about 0.001 under size, the cylinder bore will be lapped to match this. Face one end and drill the hole for the valve pin, do not drill to deep. Flip the part and turn the counterbore, then drill the center hole. Switch to a 4 jaw chuck and make the center hole flat bottom using a ¼ inch center cutting end mill. Use the 4 jaw chuck to offset the part 0.060, and then use the end mill again to cut half the slot for the connecting rod. Now move the piston the opposite direction 0.060 past center to finish the slot. Yes there

is a little wave in the side but the connecting rod is only 0.180 thick so there is plenty of clearance. Drill the wrist pin hole using the elongated area for alignment.

Cylinder Lapping: The ID of the cylinder should be lapped first with 220 grit (aprox) silicon carbide lapping compound. Don't use diamond compound, it never goes away and the engine will quickly fail. A commercial expanding adjustable blind lap can be used. The lap is a brass cylinder with a tapered thread that slowly expands its diameter. With the expanding lap start with it loose and expand in small steps as the torque lessens. In all cases watch out for the lap grabbing or binding. Clean and replace the lapping compound often it gets contaminated with metal. As the ideal size is approached switch to 400 or 600 grit compound.

If the piston is drill rod, cut 3 short lengths as laps. Turn about 0.001 from the OD of one so it can just fit in the cylinder. Add some lapping compound. The lapping compound fills the gap between part and lap so it may grab. Both the cylinder and lap get ground away, so do it again with a new lap when the first one gets to loose. The third lap should have finer lapping compound used. Instead of turning down the OD, reduce it 0.0003 using wet/dry sand paper.

The lapping will produce a uniform dull finish on the ID. It seems to take forever to get close, then you went too far. The ideal fit has some drag but can be easily pushed through the cylinder with light pressure, I use a flat toothpick, and if it does not break, it should be fine. Once the piston starts moving at speed it will burnish or polish the cylinder and get the free movement needed. The dull finish will hold oil and provide a good seal. Clean thoroughly preferably in an ultrasonic cleaner. .

Crank End Cap: Start by cleaning up some $\frac{3}{4}$ square stock in the 4 jaw chuck, use a length about 1 1/8 long. This part is a frill and not actually needed. It will help keep dirt out and make the engine look more finished. Turn the 0.623 dia and part it off. Face to correct length. This engine is based on a model aircraft engine so weight was important and the boring was added. The vent hole is important if the engine is run because some air always leaks past the piston. The compressed air can build up in the crankcase and slow or stop the engine. The 4 hole pattern in all parts is identical and drilling all of them at one time will save setup time.

Main Bearing: Start with the square left from the Crank end cap. Turn the 0.500 diameter end from cleaned up bar stock. Reverse part in lathe chuck and turn 0.623 diameter and drill/bore 0.310 hole for bearing. Make bearing from oil impregnated sintered bronze. Make the bearing 0.001 larger than the hole in the body. Press the bearing into the body. Return the part to the lathe, face it to length, drill, and ream the part for the shaft. Ream 0.001 larger than crankshaft rod (if you use 3/16 drill rod, the drill rod is undersize so ream it to 3/16). If the crankshaft still seems slightly tight, put the crank in a drill chuck and spin it to burnish the fit. When correct, it needs to spin freely many revolutions when flipped between two fingers.

Valve Block: Start by cleaning up some more $\frac{3}{4}$ square stock in the 4 jaw chuck, use a length about 7/8 long. First turning the 0.496 diameter and part off the block. Reverse the part and face to length. Drill the center hole with a #3 combination drill counter sink. Drill the hole to a depth where the 3/16 ball rests 0.060 under the square surface. The .496 diameter plug that goes into the cylinder can have its length changed to determine the cylinder compression ratio that affects how much gas will be used on each cycle.

Seating the valve ball: Drop the ball into the concave cavity in the Valve Block. Using a pin punch drive the ball into the seating area with several moderate hammer blows. When this has been done, the ball should still fall out of the seat by its own weight when the Valve Plate is turned over.

Top Block: Start with the square left from the Valve Block, Turn the 0.550 diameter. Reverse the part in the lathe. Face to length then drill all the holes.

Crank Shaft: This is a 3 piece assembly. Make the disk first. Careful layout and drilling is essential. The four .125 holes are for balance. Ream the shaft and crank pin holes so parts made from drill rod have light resistance when fitted. Use Loctite 640 to secure these parts.

Connecting Rod: Make the blank about 1 1/2 long from 3/16 diameter aluminum. Turn the center section to 0.150 diameter and add the 45 degree chamfers, then part to length. Drill the holes initially #33 (0.110) for 4-40 screws. Make the lathe chuck mounting block for turning the rod. Mount it in the 4 jaw chuck and center so the center screw head turns true. A short set screw is used in the second location. Turn one of the end bosses on the connecting rod. Reverse the part and turn the other end. Do the other side. Mount the part again with the set screw now in the center and the regular screw at the far end. Turn the center web of connecting rod. Reverse and flip to finish all the cuts. Turn 2 brass bearing inserts, enlarge the end holes in the connecting rod and press in the bearings.

Flywheel: The flywheel can be made from any heavy metal. The diameter can be reduced to 1.5 or the thickness could be reduced to 0.5. The 6 holes are not required. The setscrew can be drilled perpendicular to the axis rather than at an angle or it could even be fastened with Loctite. My steel flywheel was heated to red heat, which made a black oxide and it was finished with tung oil to prevent rust. Ream the shaft hole 0.001 larger than the shaft used.

Gaskets: Gaskets made from 0.005 thick Teflon seal well and are reusable. Paper gaskets can be used. If you don't want to punch the corner holes, cut the corners off at 45 degrees. The gaskets are needed because if the top of the cylinder leaks it will have a big impact on performance.

Assembly:

Fit the connecting rod to the piston with the wrist pin. The piston should wiggle in the connecting rod but be a close fit. Secure the wrist pin with some Loctite. Put the piston in the cylinder. Put the crankshaft in the main bearing, that fit should already be good. Put the crankshaft pin through the connecting rod hole and mount the main bearing with 1/4 long screws. Oil the moving parts. The shaft must be able to be rotated easily and the piston moves freely with no binding. If it is tight, start turning it by hand with lots of oil. A quick run powered by the lathe may also help, starting at the lowest speed and use lots of oil.

Put the valve block on the cylinder top with a gasket. **Piston pin:** The piston pin should be able to lift the ball 0 .010 to 0.020. Add the top plate with a second gasket and 5/8 long screws. If the engine is shaken, the ball can be heard rattling. Mount the flywheel, support the engine, connect compressed air, and it's done.

How the engine feels: When the engine is spun by hand, it pumps air out the compressed air inlet and makes a pop sound as the exhaust opens. The flywheel should be able to cause the engine to carry though about 4 cycles with a good flip.

Start Up Notes: The engine will start in either direction with 35 PSI applied and a gentle spin. The engine may appear to run faster one direction, but I suspect it is the way it is most often started. Keep it well oiled and it just runs. Air consumption is low. Once the engine is running it will operate in any position. The engine needs to be oiled at every starting and will operate for about 3 hours with one drop of oil. Plain #30 oil seems to work best. Dry lubricants such as Teflon spray or molybdenum work well too.

What if it does not work: I can only think of 4 reasons this engine will not run, well you might have a new one.

1. Is the engine free from binding? A good flip should carry through 4 or more cycles. There should be no tight spots and they should move smoothly.
2. Does the valve leak? The air pressure will push the valve ball closed. It should not leak air out the exhaust port when the piston is at the bottom of the stroke. If it does leak, give the ball another tap with a small hammer and pin to form a perfect seating surface.

3. Does the piston leak too much? With the piston at the top of the stroke the pin will push the ball open, air should not be rushing past the piston. If it leaks, try some 40 weight oil on the piston. Try starting with the piston pointing down and lots of oil, remember the engine runs in any position.
4. Is the crankcase getting pressurized by leaks? Take the end cover off the crankcase.
5. If all else fails just fiddle with it. Once it starts, it will get easier to start. If leaks are big it may not run well or for long. If fits are reasonable, it will just run. Reasonable fit for these engines is not good enough for internal combustion. If fits are marginal, make the parts again, most do not take that long to make.

Have fun with this engine and let it be a starting point your fun fast designs.

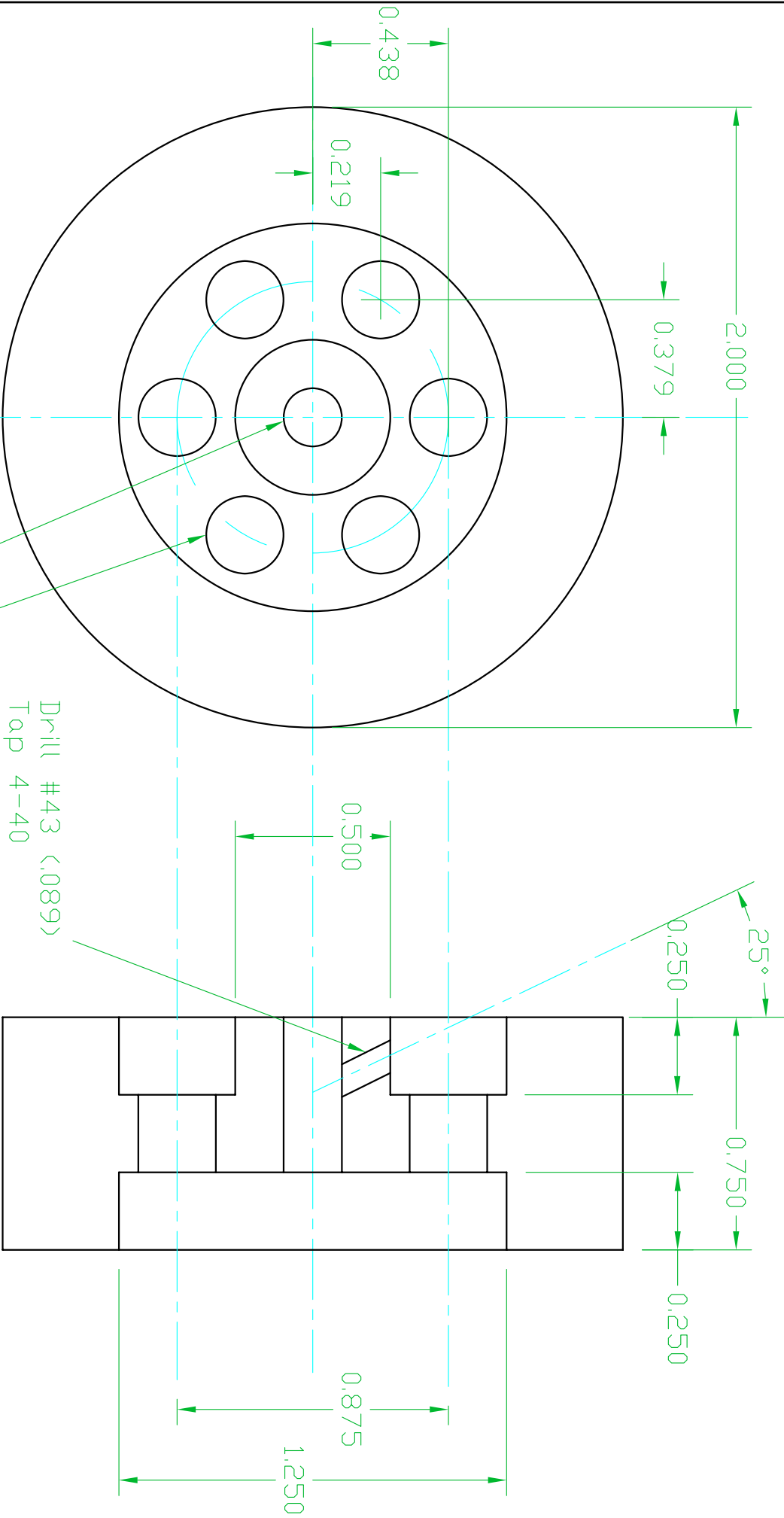

Cast Iron, SS, or Brass
Fly wheel can be smaller or
thinner.

David Kerzel
Pompano Beach, Florida USA

This drawing may be used, copied or modified for any non-profit purpose. All accuracy and safety issues are the users responsibility and the provider and originator are in no way responsible or liable.

Assembly:	
Fly Wheel	
Title:	
Fly Wheel	
Date:	7/2/2008
Revision:	20
Drawing:	
Modular_0_9	

1/2 drill rod
or Aluminum

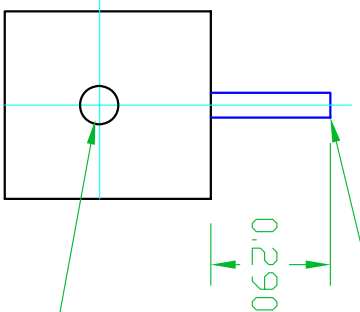
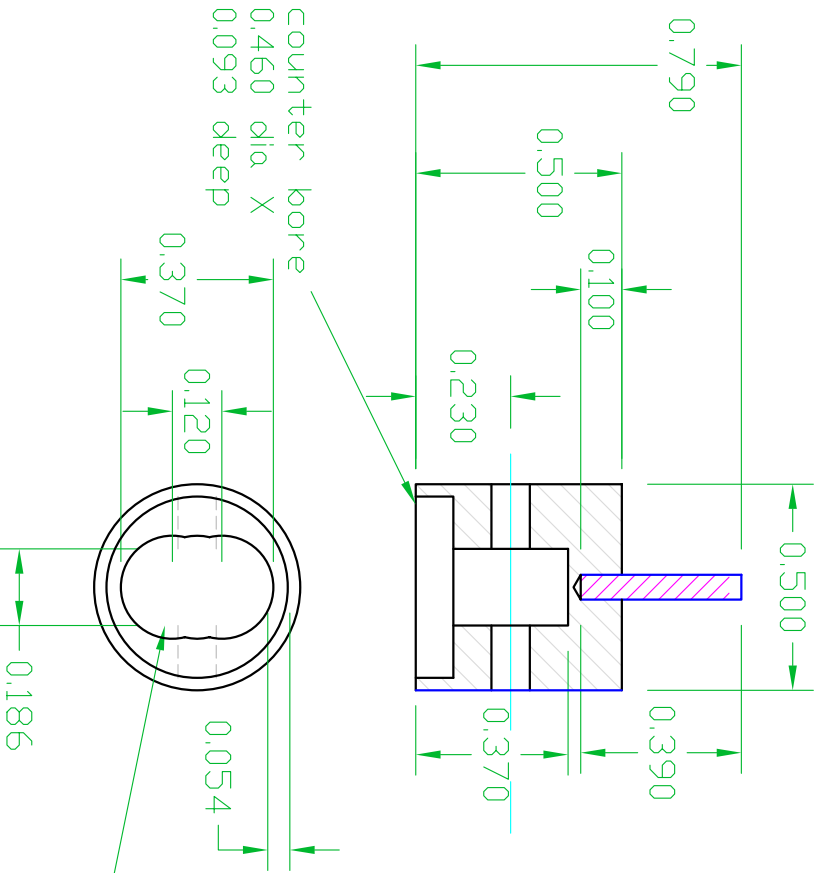

Pin is 1/16 dia
drill rod in
reamed 0.0625
hole, secure with
Loctite 640
Don't drill through
the piston.

Ream pin hole
0.093
Drill this hole,
aligned milling in
center

Mill slot with 1/4 end mill
or off set part in 4 jaw
chuck 0.060 and bore
again, offset opposite
direction and bore again.

Aluminum Piston is to be turned 0.002 oversize and lapped to
size. Exact fit will have dry piston fall through cylinder and
oiled piston will pop back up when pushed into a closed
cylinder. Drill Rod PistonDD is not adjusted.



Wrist Pin:

0.093 drill rod,
Secure to piston
with Loctite

David Kerzel
Pompano Beach, Florida USA

This drawing may be used, copied or modified for any
nonprofit purpose. All accuracy and safety issues are
the users responsibility and the provider and originator
are in no way responsible or liable.

Assembly:
Pin & Ball Valve - Piston

Title:
Piston &n Wrist Pin

Date: 6/8/2008
Revision: 20
Drawing:
Modular_0_8

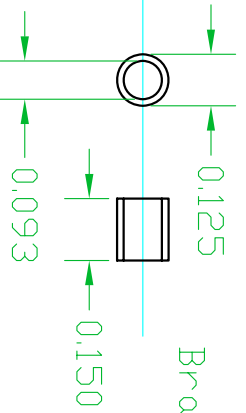

Brass inserts

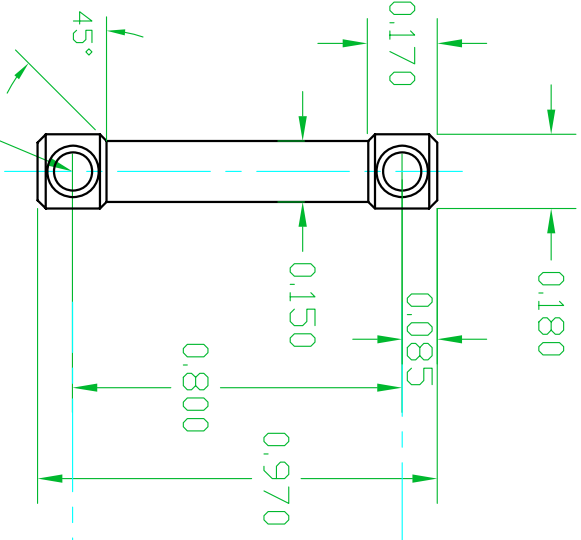

Drill #33 (0.110) for 4-40 screws for turning to thickness.
 Later drill .125 and press in brass inserts, drilled then ream .093, 2 places

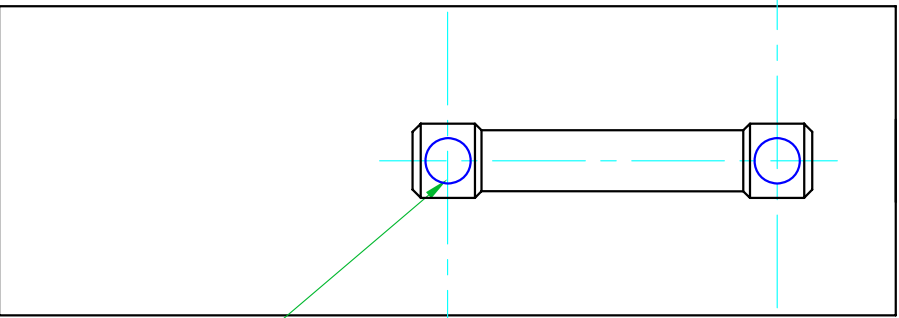

Brass or Aluminum with brass bearing inserts

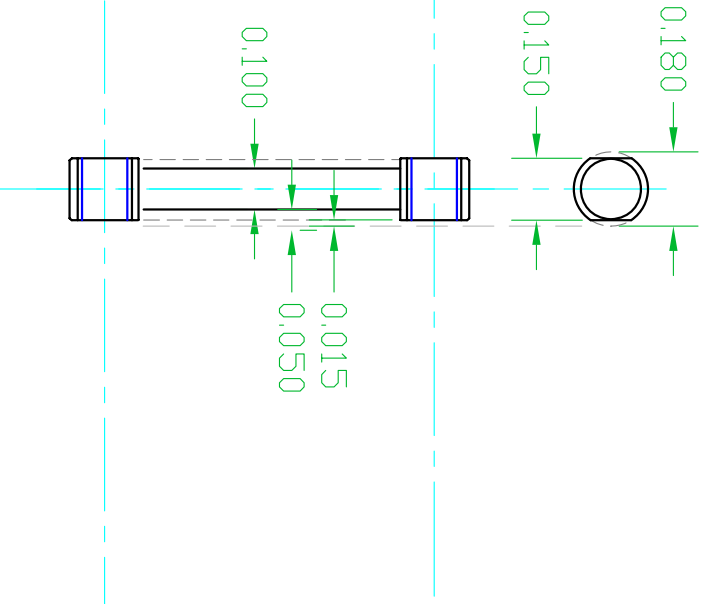

Mount blank to plate with 4-40 screw in center and set screw in far end.
 Drill plate #43 (0.089), tap 4-40

Use a plate to turn to thickness.
 Mount plate in 4 jaw chuck and turn bosses on ends, then turn center to proper thickness

David Kerzel

Pompano Beach, Florida USA

This drawing may be used, copied or modified for any non-profit purpose. All accuracy and safety issues are the users responsibility and the provider and originator are in no way responsible or liable.

Assembly:

Connecting Rod

Title:

Connecting Rod

Date: 7/6/2008
 Revision: 21
 Drawing:
 Modular_0_7

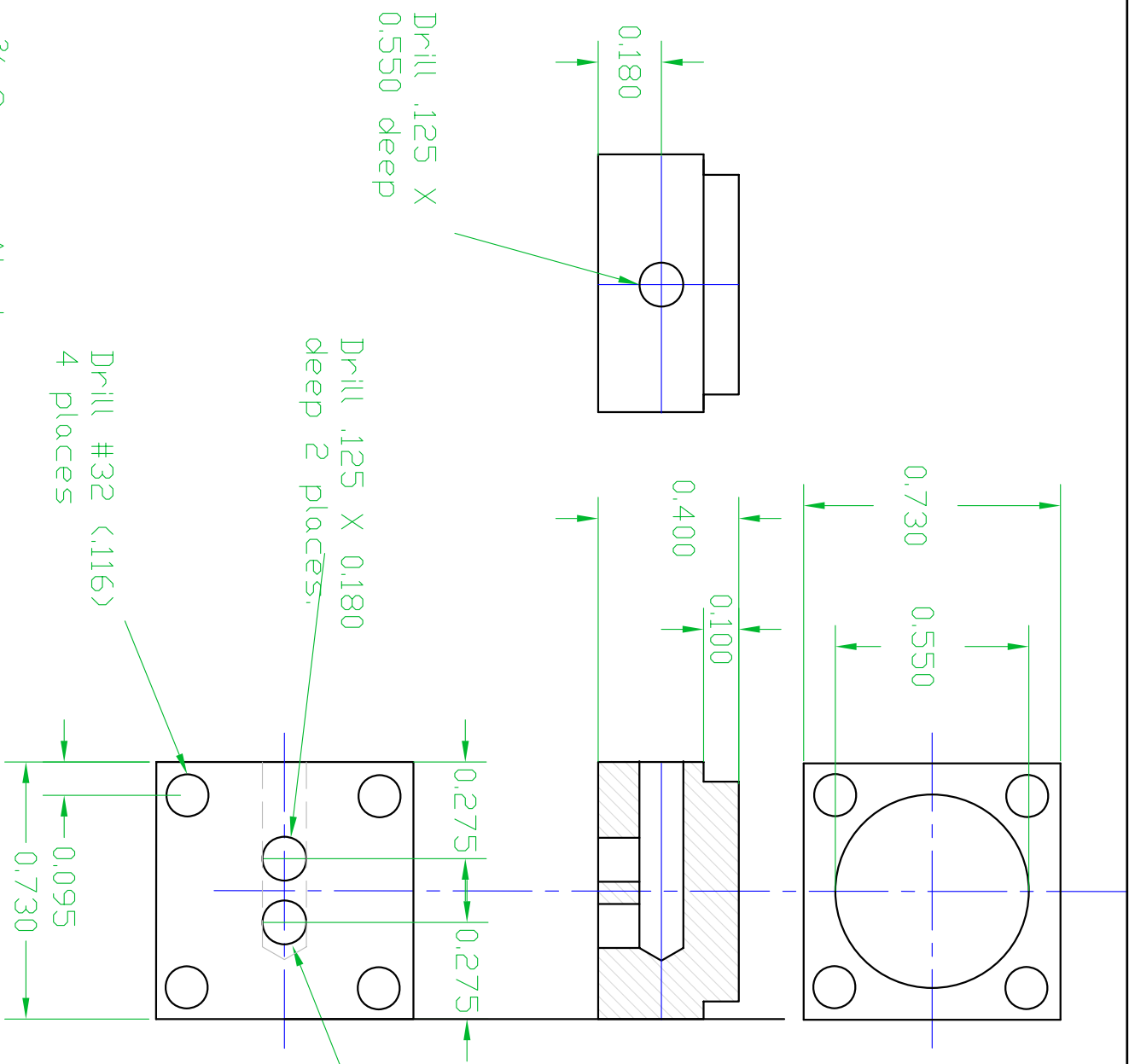

2 air inlet holes prevent ball from being pushed to one side.

3/4 Square Aluminum

David Kerzel	
Pompano Beach, Florida USA	
This drawing may be used, copied or modified for any non-profit purpose. All accuracy and safety issues are the users responsibility and the provider and originator are in no way responsible or liable.	
Assembly:	
Pin & Ball Valve - Valve	
Title:	
Top Plate	
Date: 6/17/2008	Drawing:
Revision: 20	Modular_0_6

Drill thru #3 combination
 drill counter sink(1/4 to
 $\frac{7}{64}$ at 30 degrees),
 Drill so 3/16 ball rests
 0.060 below surface.

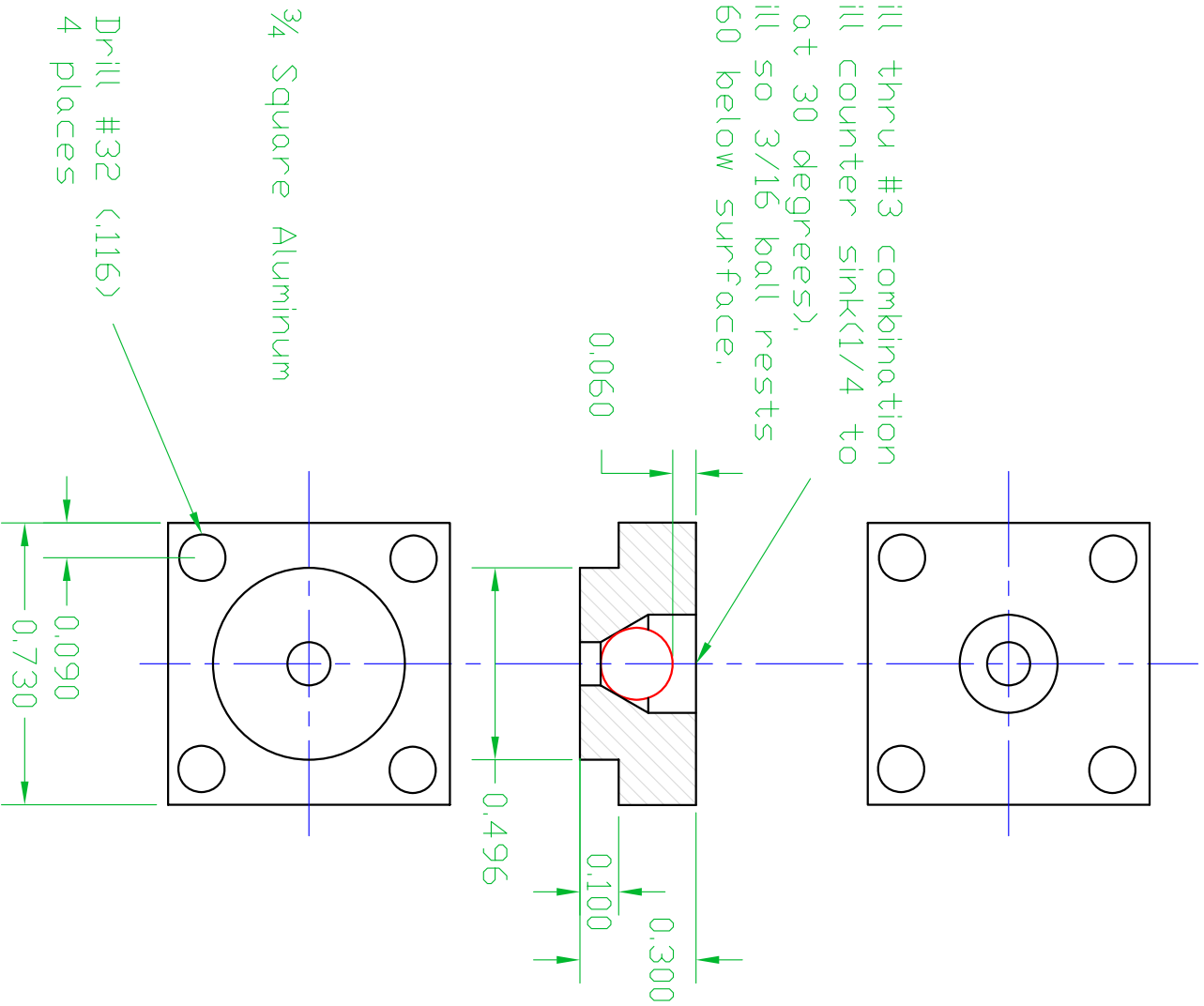

$\frac{3}{4}$ Square Aluminum

Drill #32 (.116)
 4 places

David Kerzel	
Pompano Beach, Florida USA	
This drawing may be used, copied or modified for any non-profit purpose. All accuracy and safety issues are the users responsibility and the provider and originator are in no way responsible or liable.	
Assembly:	
Pin & Ball Valve - Valve	
Title:	
Valve Block	
Date: 6/8/2008	Drawing:
Revision: 20	Modular_0_5

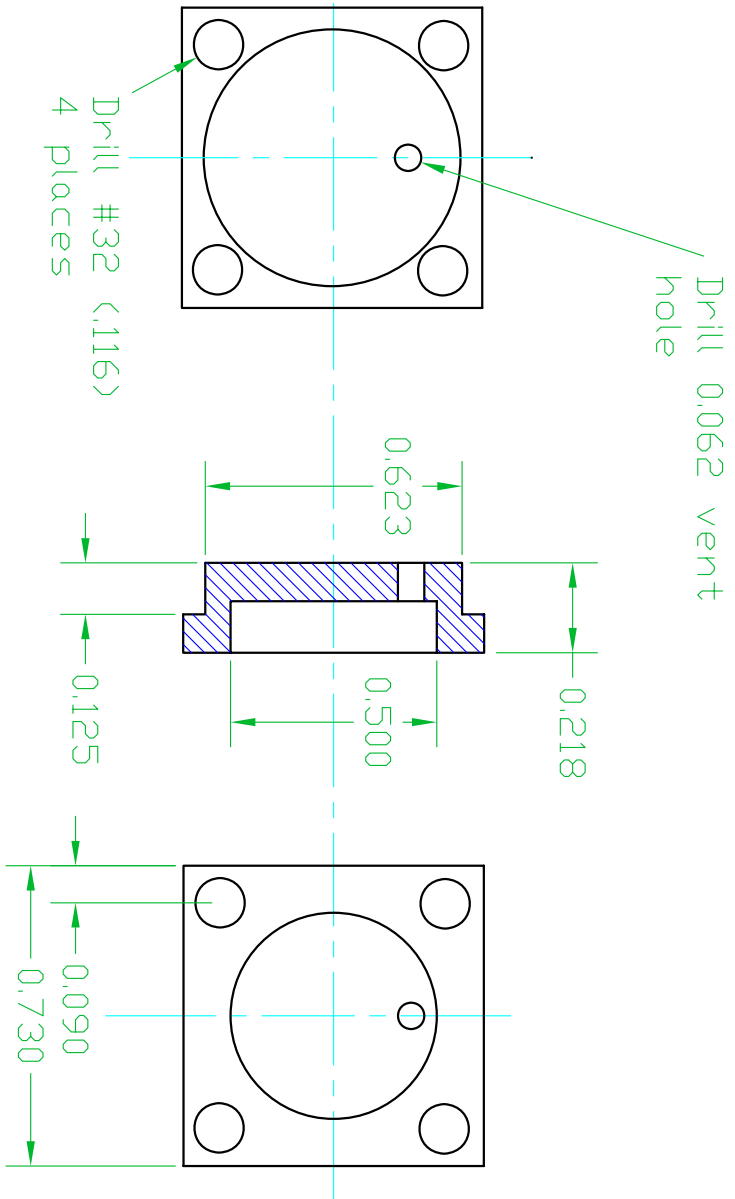

David Kerzel

Pompano Beach, Florida USA

This drawing may be used, copied or modified for any non-profit purpose. All accuracy and safety issues are the users responsibility and the provider and originator are in no way responsible or liable.

Assembly:

Pin & Ball Valve Air Engine

Title:

Crank End Cap

Date: 6/5/2002

Revision: 11 **Drawing:** Modular_0_4

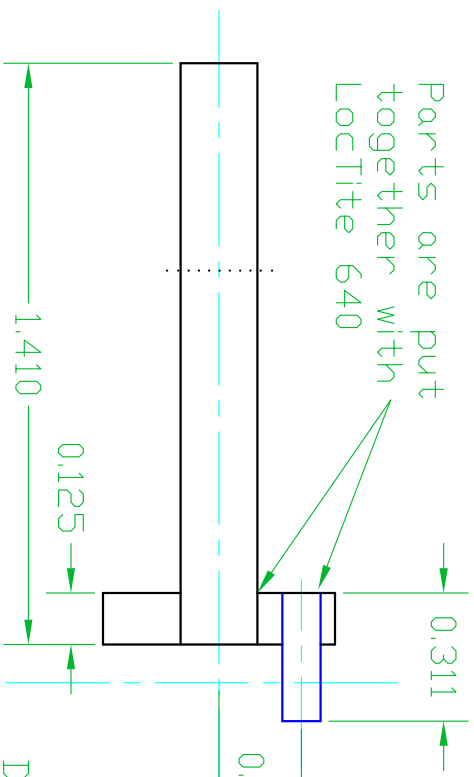

Parts are put together with Loctite 640

Shaft is $\frac{3}{16}$ drill rod
 pin is $\frac{3}{32}$ drill rod
 Disk is steel or brass

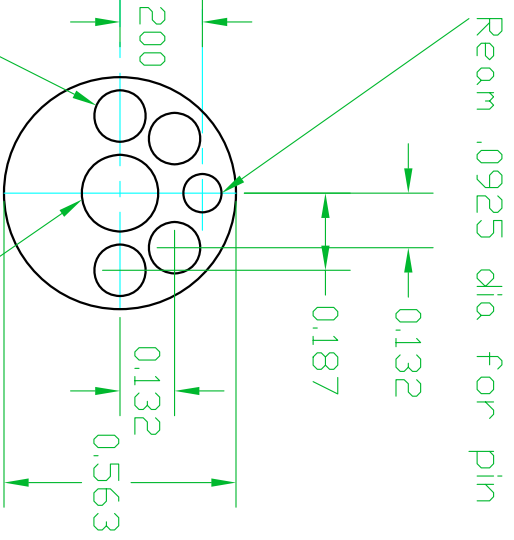

Ream .0925 dia for pin

Ream .0188 for shaft
 Drill .125, 4 places on .187 radius or use dimensions as shown

David Kerzel

Pompano Beach, Florida USA

This drawing may be used, copied or modified for any non-profit purpose. All accuracy and safety issues are the users responsibility and the provider and originator are in no way responsible or liable.

Assembly:	
Pin & Ball Valve Air Engine	
Title:	
Crank Shaft	
Date:	7/3/2008
Revision:	20
Drawing:	
Modular_0_3	

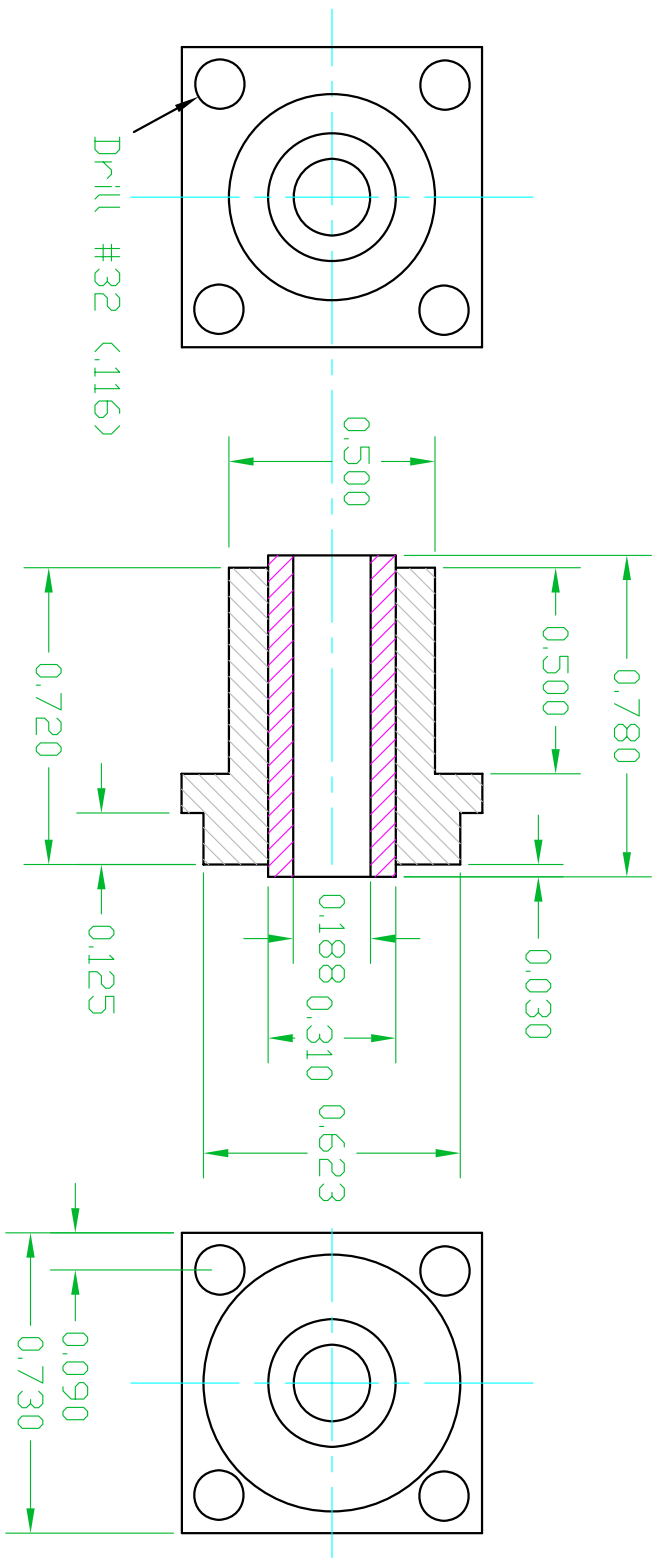

Body is Aluminum
 Bearing is oil filled sintered bronze
 Set diameters for 0.001 interference

David Kerzel

Pompano Beach, Florida USA

This drawing may be used, copied or modified for any non-profit purpose. All accuracy and safety issues are the users responsibility and the provider and originator are in no way responsible or liable.

Assembly:

Pin & Ball Valve Air Engine

Title:
 Main Bearing

Date: 3/4/2003
 Drawing:

Revision: 1.3
 Modular_0_2

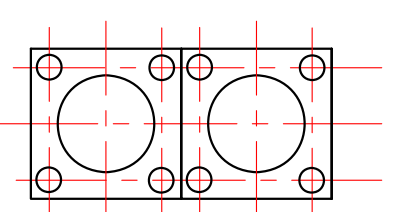
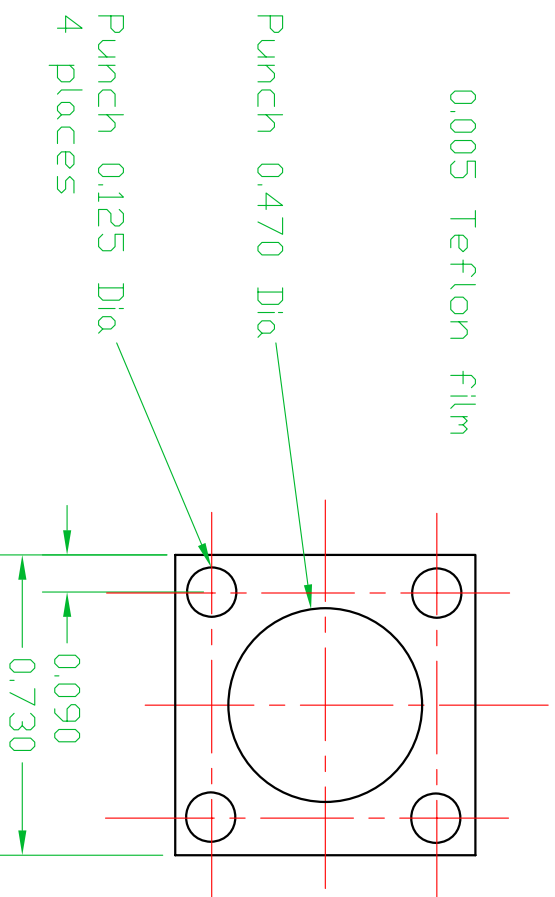

Tape Teflon film over full size drawing.
Punch holes.

Make .125 punch from .125 OD brass tube, counter sink ID to make cutting edge.
Make 0.470 punch from steel, turn to 0.470 OD bore to 0.380 dia, chamfer ID to make cutting edge at 60°. Place Teflon and drawing on wood and punch.

David Kerzel

Pompano Beach, Florida USA

This drawing may be used, copied or modified for any non-profit purpose. All accuracy and safety issues are the users responsibility and the provider and originator are in no way responsible or liable.

Assembly:

Head Gasket

Title:

Head Gasket

Date: 6/5/2002

Drawing:

Revision: 20

Modular_0_10